

Dresser Vapor Recovery Meter

Models 8C175 and 3M175

Since 1975, Dresser Utility Solutions Vapor Recover Meters (VRM) have set the standard for California Air Resources Board (CARB) approved Gas Volume Meters. The Dresser VRM is designed for, tested and approved by CARB. As Air Resources Board specifications change, we quickly respond with product enhancements to maintain our approval to Executive Order G-070, Source Test Procedure ST-39 – Regulation 8-7-302, and other associated Test Procedures such as TP-201.1, TP-201.1A, TP-201.2, TP-201.3, TP-205 and TP-201.5.

The Dresser 8C175 PX has a non-compensated, high frequency pulse transmitter using solid state construction to eliminate mechanical switches for maximum reliability and minimized maintenance. A mechanical odometer is not included. The meter maximum base rated capacity is 800 CFH.

The Dresser 3M175 Vapor Recovery Meter has a direct reading odometer-type index with minimum increments of 0.2 cubic feet for minimum readability of 0.1 cubic feet. Precision is ± 2 percent of the gas volume reading, or better. It is available with a low frequency (TPWS) or high frequency pulse output (CEX). The meter maximum base rated capacity is 3,000 CFH.

Features

- Provides a non-compensated, high frequency pulse output
- Designed for accurate measurement in low pressure recovery systems
- Electrical output signal ensures maximum reliability by using Solid State construction to eliminate mechanical switches
- Available in two models: 8C175 and 3M175

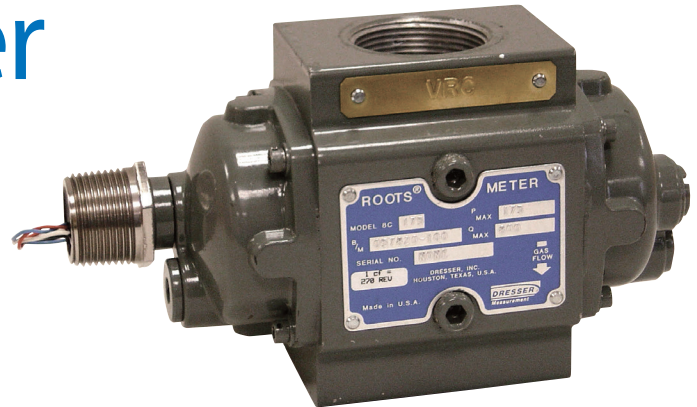

Dresser Series A-8C175 VRM MEX meter

Gasoline Dispensing Facility Apparatus requires a low pressure drop across the gas volume meter. The extremely low pressure drop characteristic of the Dresser rotary positive displacement meter makes it the most suitable for these specialized applications. Our 3M175 VRM does not exceed 1.10 inches H₂O at 3,000 CFH or 0.05 inches H₂O at a flowrate of 30 CFH. The 8C175 VRM does not exceed 0.70 inches H₂O at 800 CFH or 0.04 inches H₂O at a flow rate of 16 CFH.

All Dresser Vapor Recovery Meters are supplied with a 7-point certified accuracy curve resulting from tests on a bell prover certified by NMI and dimensionally traceable to the National Institute of Standards and Technology (NIST) and NMI.

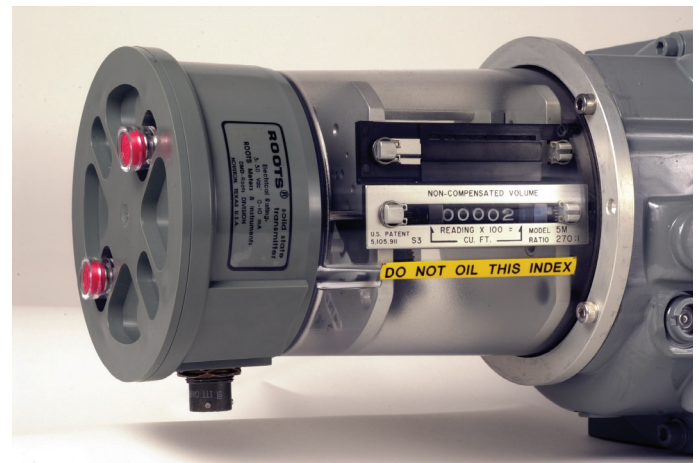

Dresser Series B3-3M175 VRM CEX meter

Specifications

	Units	Imperial
Temperature Range	deg. F	-40° to +140°
Base Rating (Q max)	acfh	800
Max. Operating Pressure (MAOP)	psig	175
Leak Test (125%) (MAOP)	psig	219
Static Test (2 x MAOP)	psig	350
Rangeability (+/- 1%)	ratio	22 : 1
Rangeability (+/- 2%)	ratio	67 : 1
Start Rate	cfh	1.13
Stop Rate	cfh	0.92
Flow Rate @ 0.5" w.c., Gas	cfh	696
Differential, 100% Flow	n. w.c.	0.64
Max. Pressurization Rate(*)	psig/sec	5
Max. Operating Speed	rpm	3600
Gear Ratio	ratio	No counter
Displaced Volume/Rev.	cf	0.003703
Pulse per Unit	1 cf =	270 pulses
Oil - Not required		
Nominal Pipe Size	in.	1-1/2 NPT
Net Weight	lbs.	6

For years, Dresser Meters have been the preferred Vapor Recovery Meter to measure the volumetric flowrate through the A/L adapter.

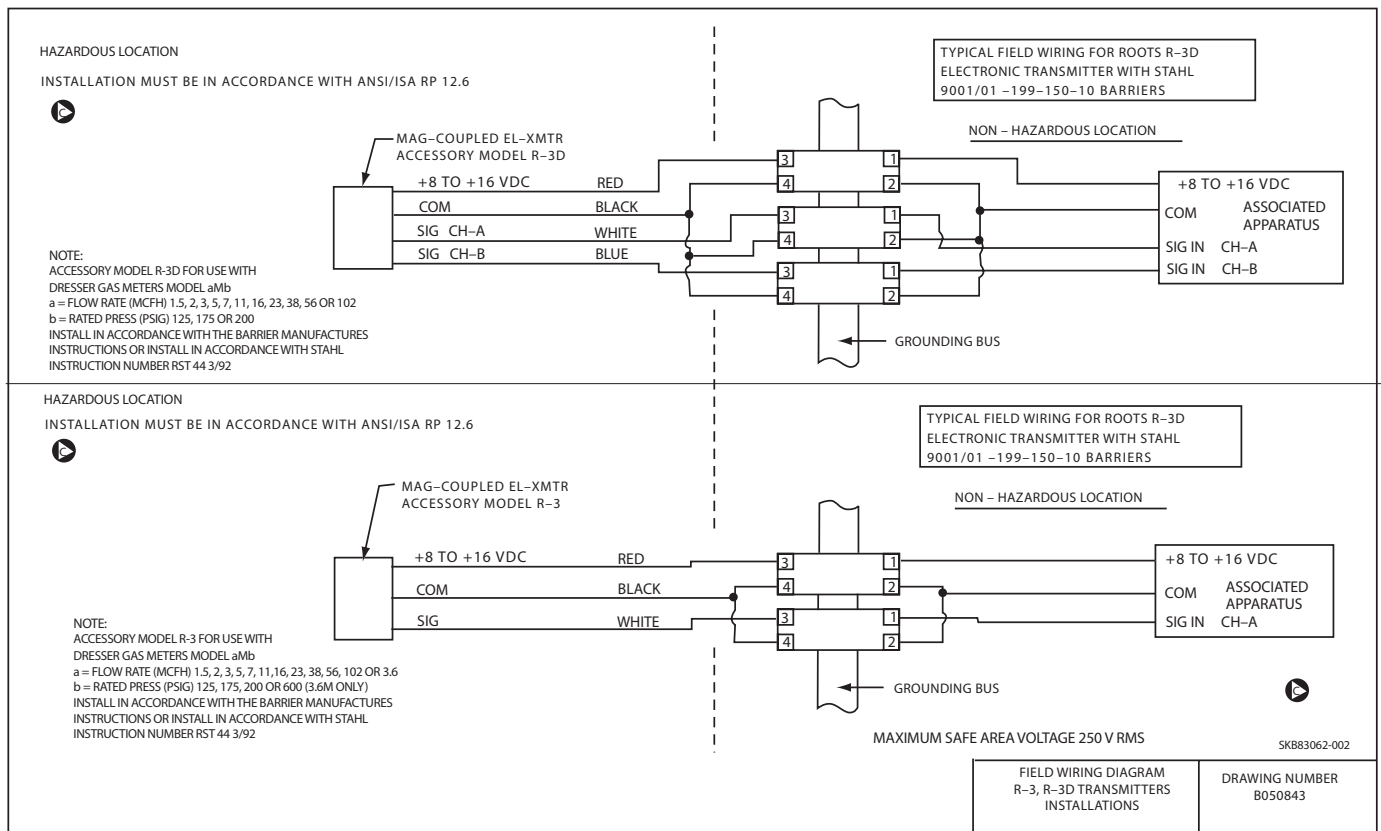
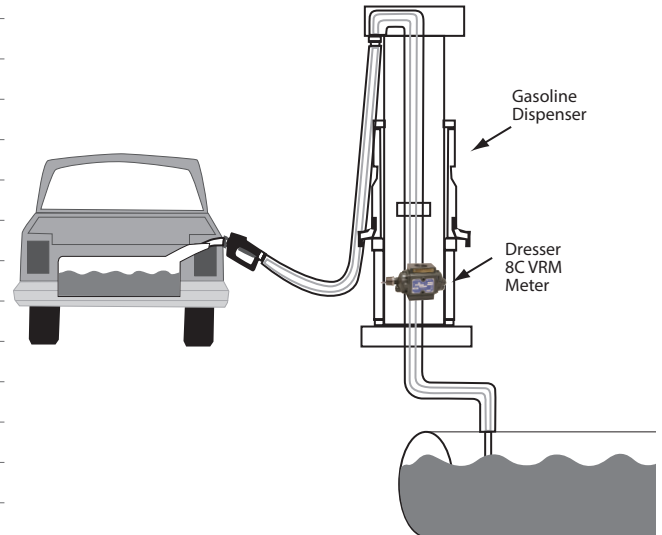

Specifications: Dresser 3M VRM Meter

	Units	Imperial
Temperature Range	deg. F	-40° to +140°
Base Rating (Q max)	acfh	3000
Max. Operating Pressure (MAOP)	psig	175
Leak Test (125%) (MAOP)	psig	219
Static Test (2 x MAOP)	psig	350
Rangeability (+/- 1%)	ratio	76 : 1
Rangeability (+/- 2%)	ratio	139 : 1
Start Rate	cfh	2.1
Stop Rate	cfh	1.8
Flow Rate @ 0.5" w.c., Gas	cfh	2580
Differential, 100% Flow	in. w.c.	1.05
Max. Pressurization Rate	psig/sec	5
Max. Operating Speed	rpm	2000
Gear Ratio	ratio	400:1
Displaced Volume/Rev.	cf	0.025
Nominal Pipe Size	in	2
Flange-to-Flange	in	6-3/4
Flange Connection	ANSI	150#FF
Bolts per Flange	qty.	4
Bolt Size ¹	in	5/8 - 11
Flange Bolt Hole Depth	in	15/16
Bolt Torque: Lubricated/Non-Lub	ft-lb	55/60
Oil Capacity - Side Inlet	oz.	1.25
Oil Capacity - Top Inlet	oz.	7.65

¹ Bolt Length varies by application.

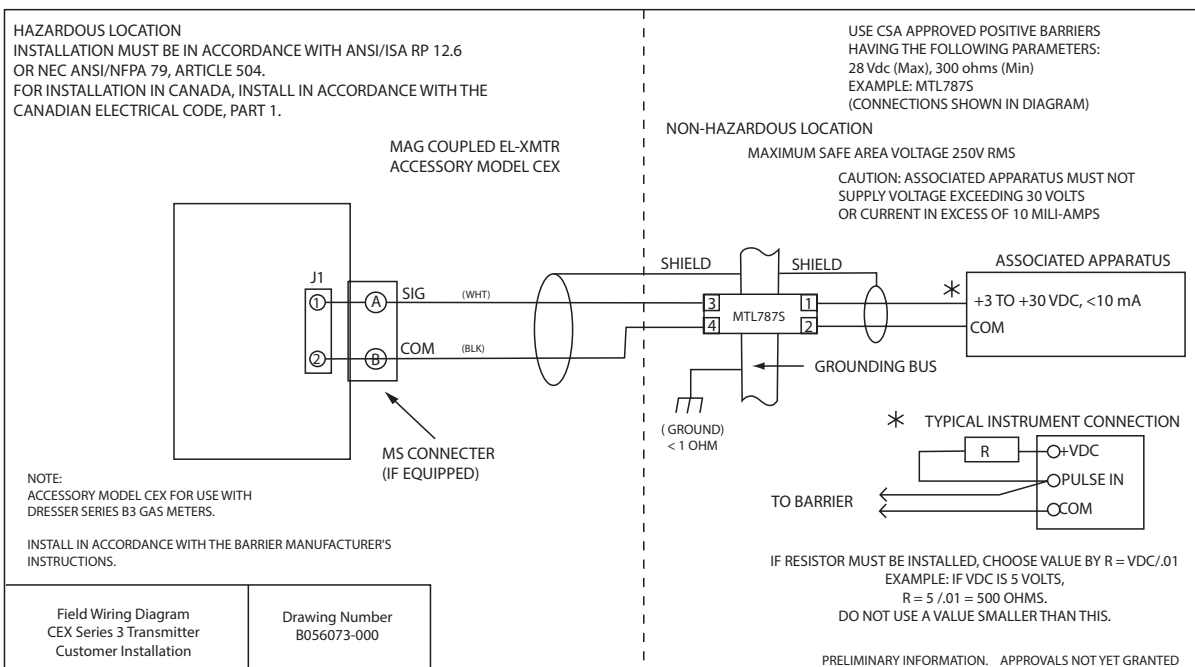

Specifications

DIMENSIONS

8C VRM	C	L	M	N	O	P	R	Approx. Weight
VRCPX	8.18	3.55	3.40	1.23	3.31	4.75	1.66	5.2 lbs

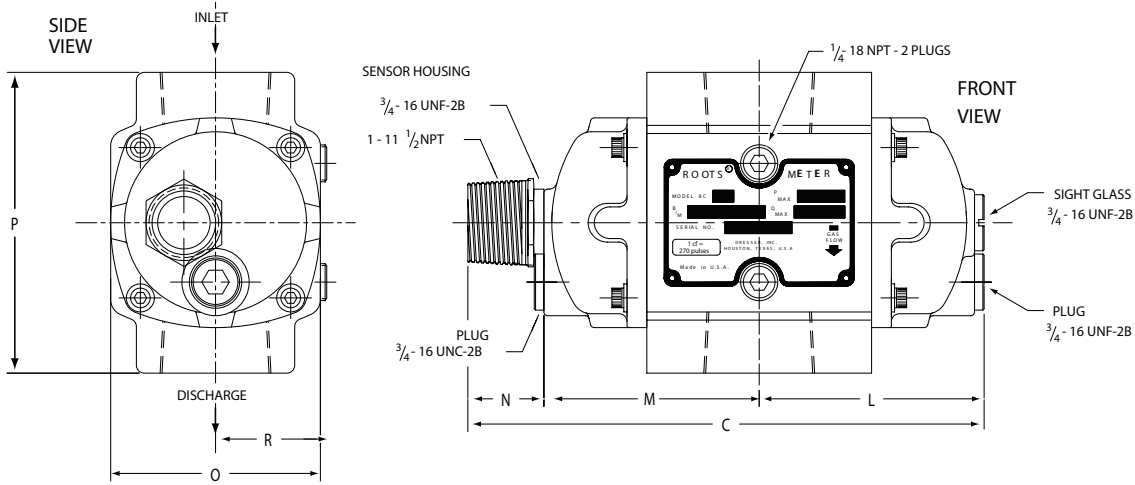

DIMENSIONS

3M VRM	C	L	M	N	O	P	R	Approx. Weight
VRCPX	18.03	5.66	12.375	7	6.97	6.75	3.48	26.5 lbs

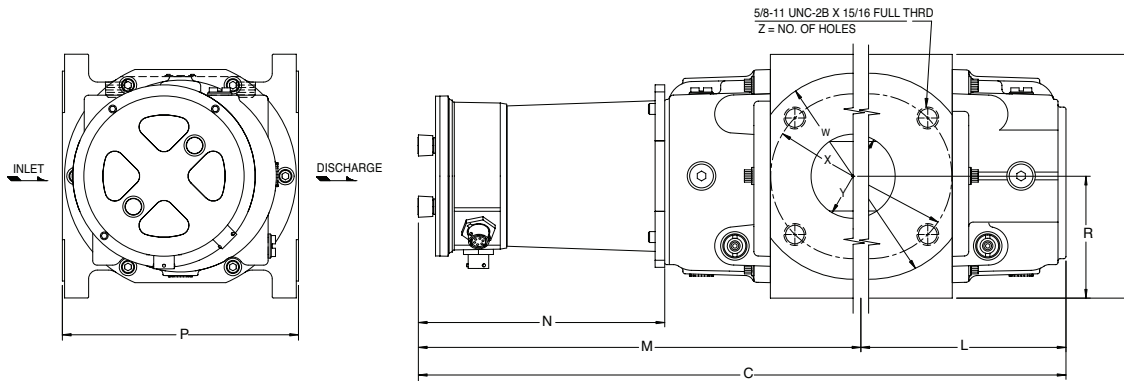

To order:

Specify meter Series, Size and Type (i.e. 3M175 VRM Dresser Series B3 meter).

8C175PX, 8C175CTR, 3M175CTR, 3M175 CPWS1, 3M175CEX.

1Specify Single or Dual Connectors and Connector Type (MS Circular, Conduit or Cable Gland).

8C15CTR VRM is available but is not currently CARB approved.

Contact the Factory for other available information, options, or special requests.

Dresser Measurement

16240 Port Northwest Drive

Houston, TX 77041

T: 1-800-521-1114

F: 1-800-335-5224

The Dresser Logo and all Trademarks containing the term "Dresser" are the property of Dresser, LLC, a subsidiary of Baker Hughes.



Dresser Vapor Recovery Meter Fact Sheet NGS.MI.0028a

11.21